

SeIII series (60-2200Ton)

The benchmark for high-performance injection moulding machine



SeIII series (60-2200Ton)

The benchmark for high-performance injection moulding machine

WELLTEC



Upgraded components with SeIII

- Guide rail added for injection unit
- Mould height adjustment by gear for 90-160T
- Hopper sliding device for 90- 320T
- European style ejector
- Built-in oil cooler
- Fully enclosed injection unit

New generation upgrades

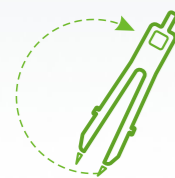

Opening stroke
increased by up to
15%



Ejector stroke
increased by up to
20%



Mould thickness
increased by up to
15%



Max. daylight
increased by up to
55%



Ejector force
increased by up to
40%

Features

- **30%** higher energy saving than using traditional variable pump
- Stable and smooth movement supported by AC servo motor
- Effective reduction of energy consumption due to reduced oil and cooling water attained by hydraulic system
- High performance European B&R control system

SeIII series (60-2200Ton)

The benchmark for high-performance injection moulding machine

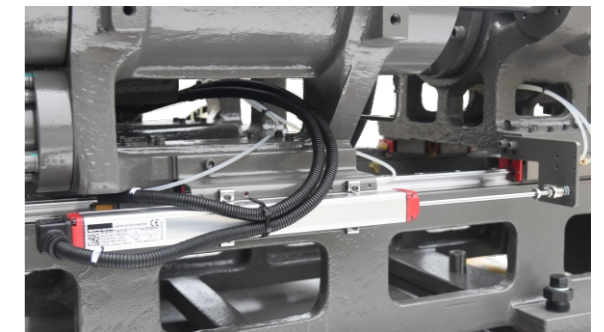
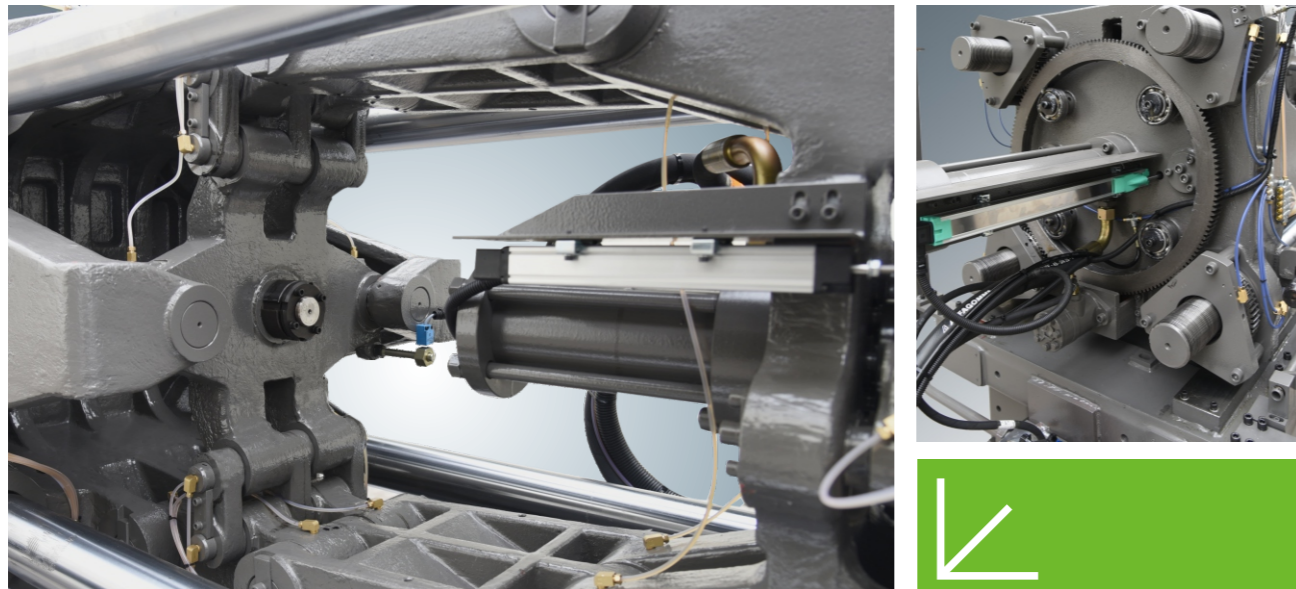

Injection Unit

- Newly optimised injection unit design to enable various production needs
- Diagonally located cylinders to facilitate better stress distribution
- Linear guide rail significantly reduces mechanical wear and tear (90-850SeIII)

Clamping Unit

- Extra durability achieved through optimised clamping structure
- Optimised platen design to disperse stress
- Accurate pause and smooth and speedy movement supported by strengthened toggle
- High pressure lubrication system adopted in clamping unit to support machine protection during high speed production
- The toggle's special heat-treated steel case enables higher wear resistance
- High-rigidity frame supports smooth movement

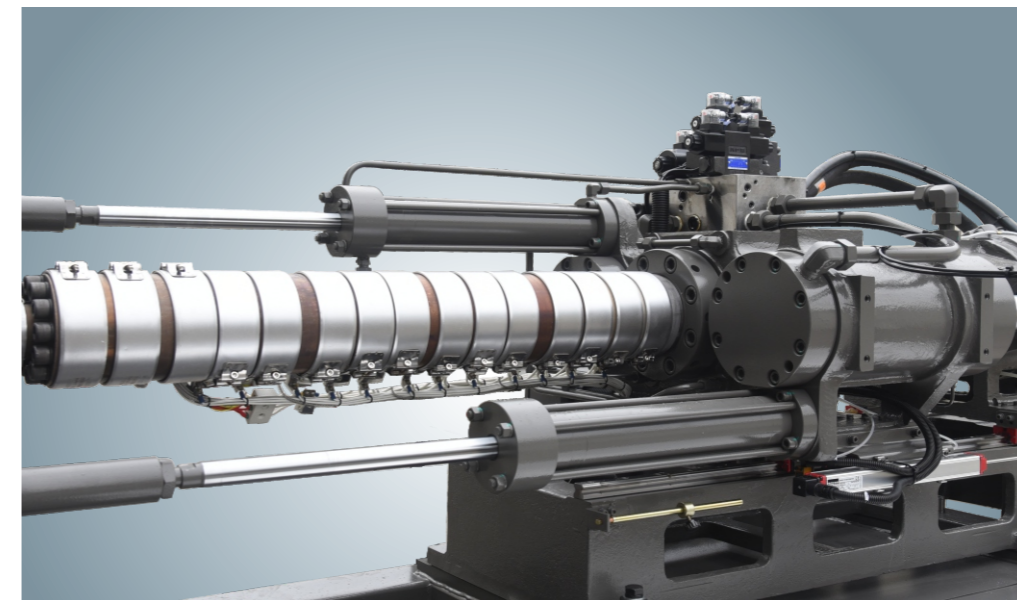
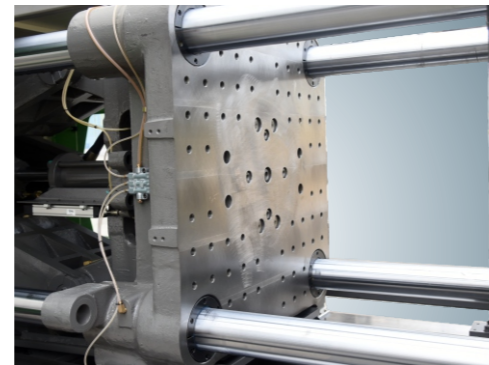

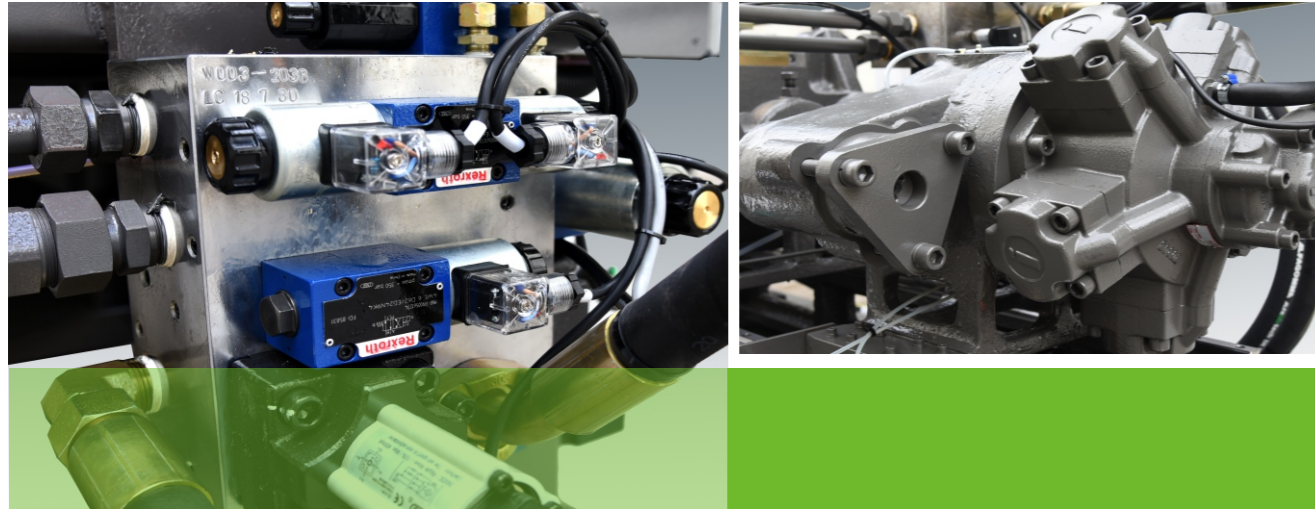

Hydraulic System

- Efficient and stable servo hydraulic system
- Minimised energy loss attained through the advanced hydraulic pipeline design
- Low-noise
- Advanced servo pump improves machine performance

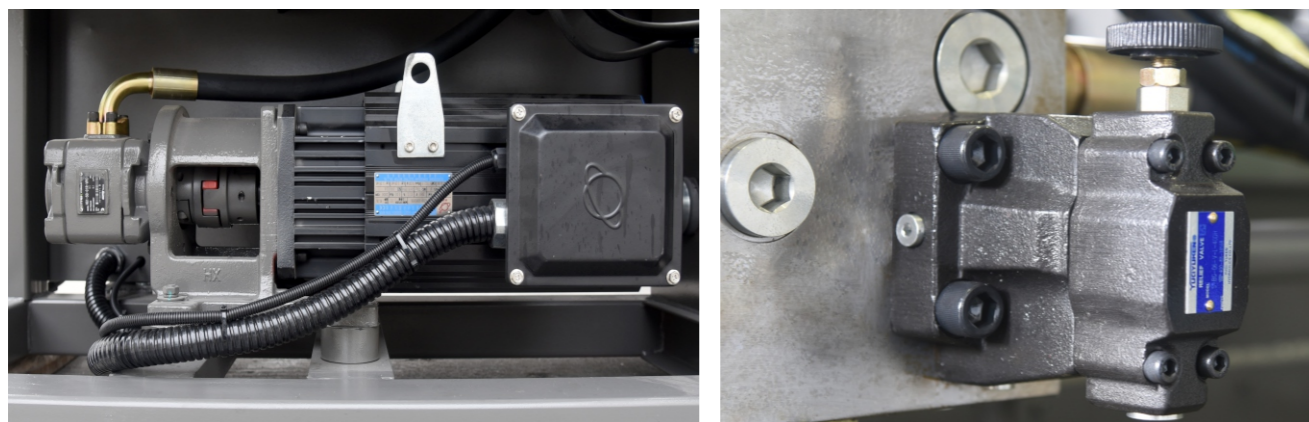

Software & Functions



S09 smart control system

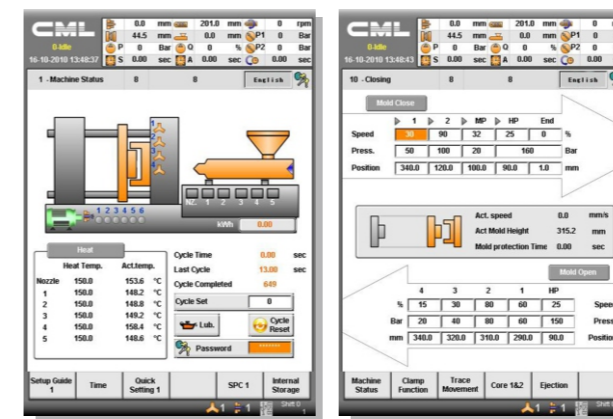

- High performance European B&R control system
- 10.4" TFT colour LCD display
- Users can identify the changes of parameter and sources of the changes
- Parameter data statistics for quality control
- Auto control of temperature by PID
- Mould parameter can be stored in USB devices and used in another injection moulding machine
- Remote monitoring of parameter and operation sequence by MODEM or Ethernet
- Multi-language selection

iSee Facilitates real-time monitoring, remote diagnosis and smart factory management (optional)

Standard and Optional Features

standard ● optional ○

Injection Unit

Nitrided screw	●
Movable hopper (90-320T)	●
Fixed hopper (380-660T)	●
Barrel protective cover	●
Injection / holding pressure/ plasticising setting	●
Screw cold- start prevention system	●
Automatic heat preservation and heating device	●
Anti-drooling function	●
Automatic purging system	●
Automatic injection failure detection	●
Purge guard	●
Reduced/ enlarged ONE STEP injection unit	○
Extended nozzle	○
Spring-loaded nozzle	○
Hydraulic/ Pneumatic shut-off nozzle	○
Material loading platform	○
Electric plasticising	○
Linear transducer for injection carriage	○
Wide varieties of screw and barrels for engineering, recycled and glass fiber composed resins	○

Clamping Unit

High pressure centralised lubrication system	●
Hydraulic and electrical safety device	●
Multi-function ejector control	●
Fast mould-close function (160- 2200 T)	●
Auto mould height adjustment	●
Mould ejector backward device	●
Increase mould thickness range	○
SPI mounting hole platens	○
Quick mould change system (T-slot necessary)	○
Increase ejector force	○
Increase ejector stroke	○
Retractable tie bar	○
Mould hanger	○

Hydraulic Unit

Closed-loop servo control of pressure and flow rate	●
Adjustable back pressure control	●
Y- strainer for water cooling	●
Special servo motor and servo drive	●
High-performance servo pump	●
Core pulling (fixed / movable platen)	○
Unscrew device with motor	○

Oil level sensor and alarm	○
Plasticising during mould opening	○
Ejector on fly	○
Injection accumulator	○
Proportional direction valves for clamping	○
Hydraulic / Pneumatic sequential injection	○
Enlarged motor & pump (hydraulic circuit)	○
Solenoid valve for oil cooler to control water flow	○
Extra air blast	○

Control Unit and Electric Components

TFT colour LCD display	●
B&R control system	●
Multi-lingual display	●
PID temperature control	●
Heating control contactor	●
Mould data locking function	●
Speed limitation device	●
Fault alarm	●
SPC analysis	●
Robot interface	●
Individual power plug of different voltages	○
Voltage stabiliser	○
Power meter	○
Solid state relays	○
Hot runner control	○
Ceramic / Infrared heater bands	○
Robot interface (EUROMAP 12/ 67)	○
Lighting inside electric cabinet	○
Electric unscrew (Device interface)	○
Air conditioner for electric cabinet	○
Circuits check for heater bands	○
iSee software - intelligent management system	○

Others

Water flow regulator	○
Widened guard door	○
Full guard cover (for top of tail platen)	○
Sliding top cover	○
Electric automatic guard door	○
Non-standard machine colour	○

SeIII series (60-2200Ton)

The benchmark for high-performance injection moulding machine



Specifications

ITEM	UNIT	750SeIII			850SeIII			1000SeIII			1250SeIII			1500SeIII			1800SeIII			2200SeIII		
		7500/3322			8500/3322			10000/4191			12500/6152			15000/8309			18000/9586			22000/13210		
Injection unit																						
Screw diameter	mm	90	100	110	90	100	110	110	110	125	110	125	140	125	135	145	135	145	160	140	160	180
Theoretical shot volume	cc	2990	3691	4467	2990	3691	4467	4467	4657	6013	5293	6835	8574	7915	9232	10651	9232	10651	12969	11238	14678	18576
Shot weight (PS)	g	2691	3322	4020	2691	3322	4020	4020	4191	5412	4764	6152	7717	7124	8309	9586	8309	9586	11672	10114	13210	16719
Shot weight (PS)	oz	95	117	142	95	117	142	142	148	191	168	217	273	252.	294	339	294	339	412	357	467	591
Length/diameter ratio	L/D	22.6	20.0	18.0	22.6	20.0	18.0	18.0	20.0	17.7	23.3	20.8	18.5	23.0	21.1	19.7	21.1	19.7	17.8	24.9	22.0	19.5
Injection pressure	MPa	212	171	142	212	171	142	142	17	134	233	180	144	218	187	162	187	162	133	221	169	134
Injection rate	cm ³ /sec	572	706	854	572	706	854	854	787	1017	650	839	1052	695	810	935	1053	1215	1480	1024	1338	1693
Injection stroke	mm	73	90	121	73	90	121	121	118	154	106	151	184	117	146	173	189	225	235	144	203	261
Max. screw speed	rpm	470			470			490			557			645			645			730		
Plasticising capacity (PS)	g/s	124			124			115			104			81			105			70		
Injection unit force	Ton	19.8			19.8			19.8			19.8			28.8			28.8			29.0		
Carriage stroke	mm	600			600			650			800			800			850			1080		
Clamping unit																						
Clamping force	Ton	750			850			1000			1250			1500			1800			2200		
Max. daylight	mm	2050			2200			2300			2600			2900			3000			3700		
Clamping stroke	mm	1025			1100			1150			1300			1500			1500			1900		
Distance between tie bars	mm	1000x1000			1060x1060			1100x1100			1250X1250			1400X1400			1600X1400			1800X1600		
Min. mould dimension	mm	700X700			740x740			780X780			875X875			980X980			1100X980			1260X1100		
Mould thickness range	mm	350~1025			450~1100			450~1150			500~1300			600~1400			700~1500			900~1800		
Ejector force	Ton	25			25			25			25			33			33			39		
Ejector stroke	mm	350			350			350			350			350			380			450		
No. of ejector pins	unit	21			21			21			21			33			33			33		
Power unit																						
Max. motor power	kW	83.8			83.8			94.2			112			112			131.9			148.7		
System pressure	MPa	17			17			17			17			17			17			17		
Hydraulic pump capacity	L/min	440			440			495			550			550			715			825		
No. of heating zones	unit	5+1			5+1			5+1			5+1			5+1			5+1			5+1		
Heating power	kW	50			50			58			74			92			92			123		
Total power	kW	132.8			132.8			151.2			185			203			222.9			272.2		
Total current	A	161.4			161.4			182.6			224.9			246.7			270.9			330.9		
General																						
Machine net weight	Ton	39.1			43.0			52.0			68.2			100.0			125.0			169.0		
Oil filling capacity	L	1500			1500			1600			1600			2000			2000			2300		

We are always working on improvement and reserve the rights to change design and specifications without prior notice

Machine Dimensions

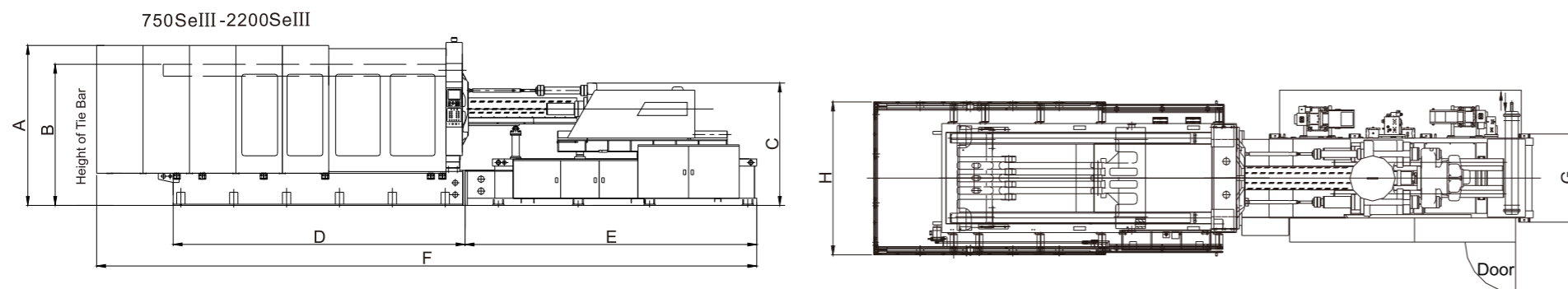

Model	A	B	C	D	E	F	G	H
750SeIII	2539	2227	2635	4318	4497	10192	1410	2295
850SeIII	2420	2300	2635	4668	4497	10514	1410	2340
1000SeIII	2687	2370	2717	4904	4900	11090	1482	2569
1250SeIII	2867	2530	2853	5485	5060	12149	1482	2812
1500SeIII	2808	2700	3200	6158	5360	13290	1340	2971
1800SeIII	2808	2720	3200	6340	5360	13439	1340	3210
2200SeIII	3267	3240	3580	7675	7298	16724	1555	4085

Remark: C-hopper height for reference only

Platen/Nozzle Dimensions

60SeIII

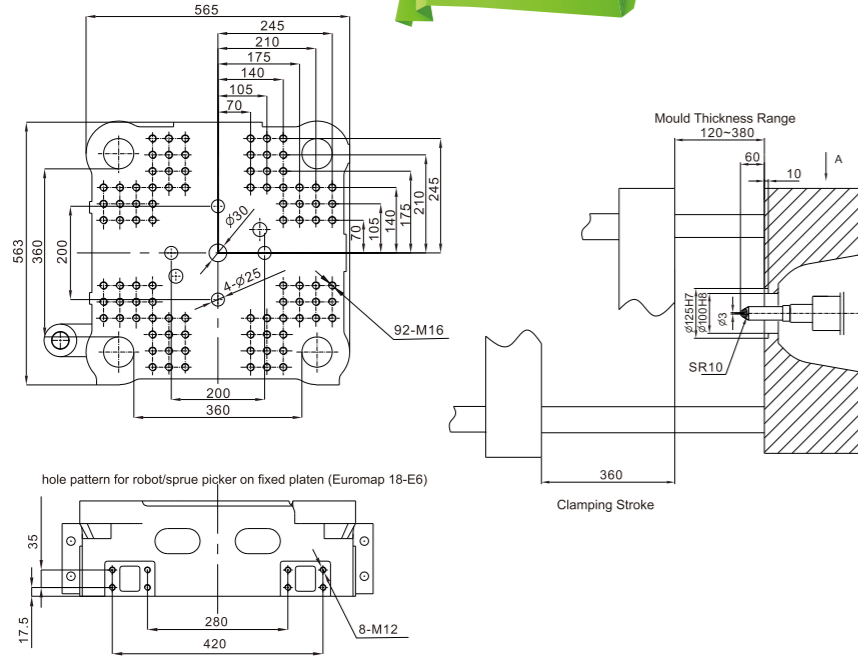

90SeIII

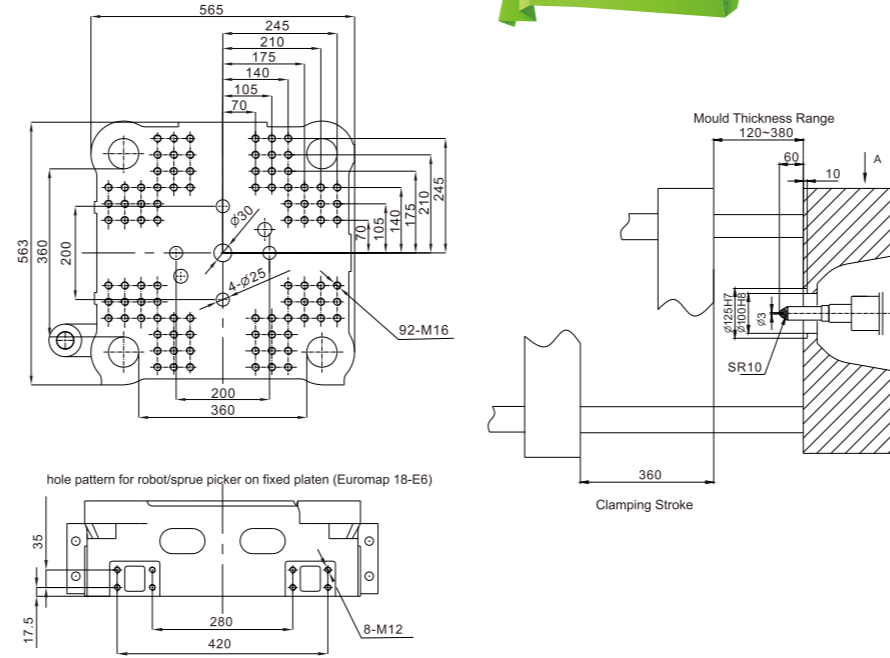

130SeIII

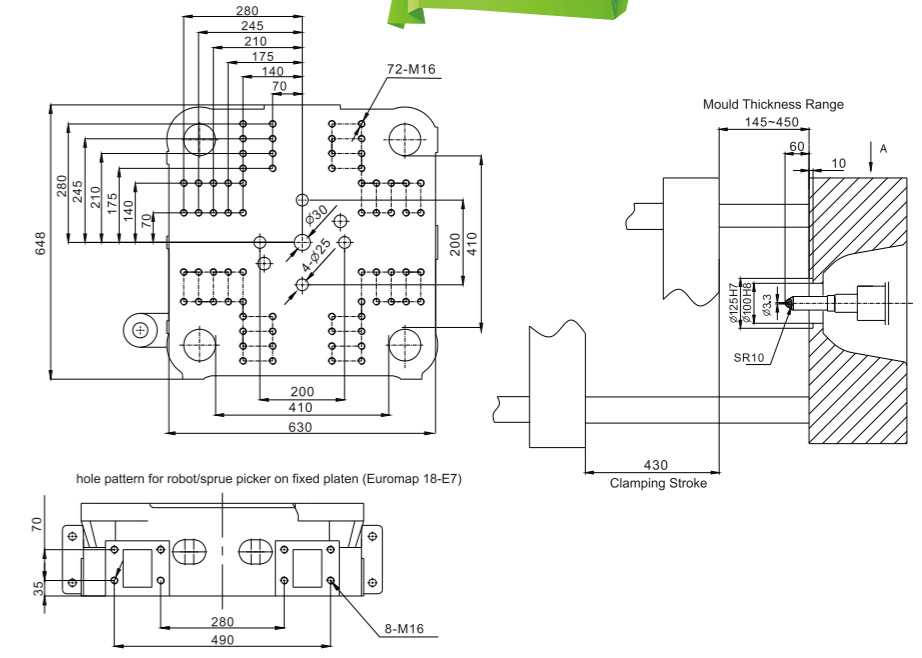

160SeIII

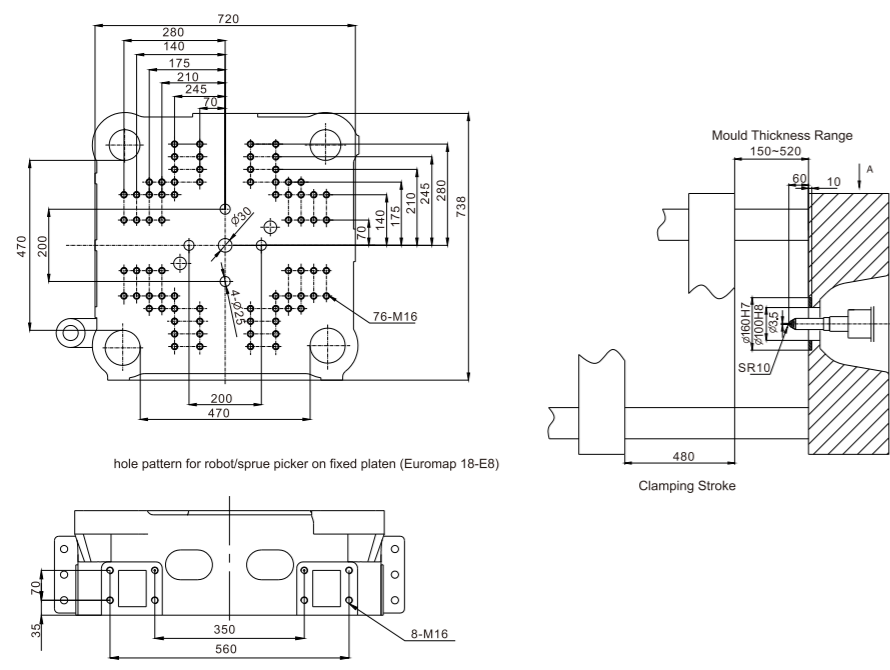

200SeIII

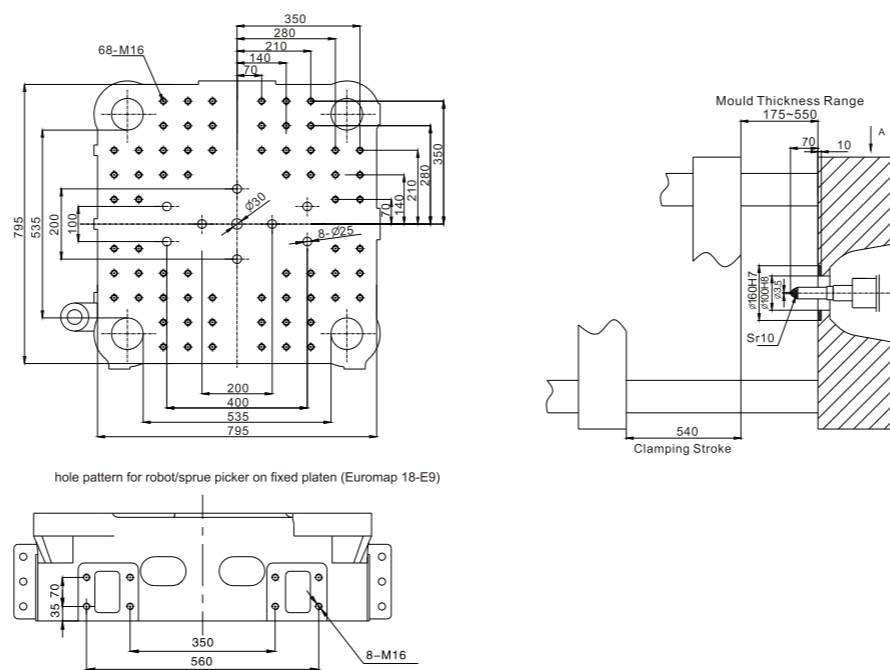

260SeIII

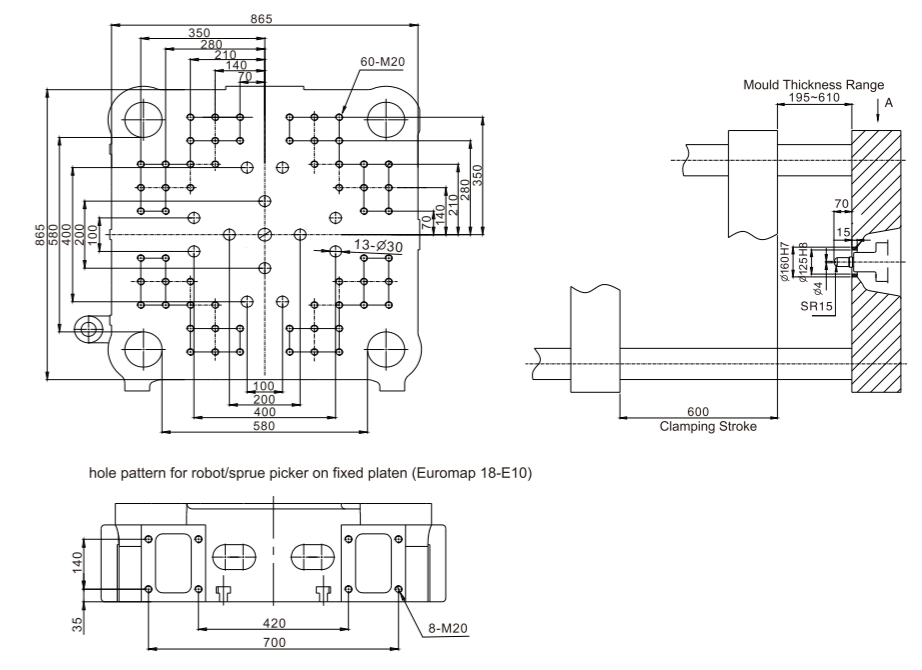

Platen/Nozzle Dimensions

320SeIII

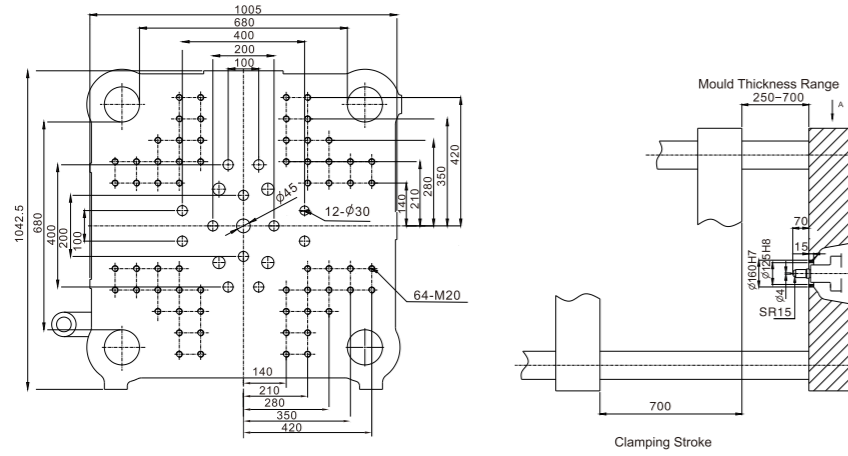

hole pattern for robot/sprue picker on fixed platen (Euromap 18-E11)

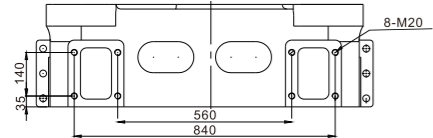

380SeIII

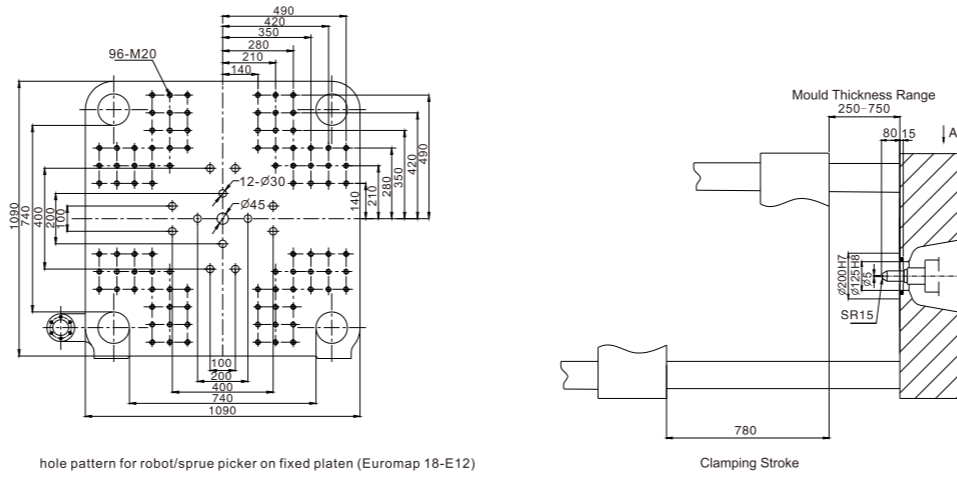

hole pattern for robot/sprue picker on fixed platen (Euromap 18-E12)

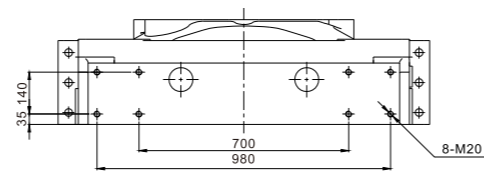

450SeIII

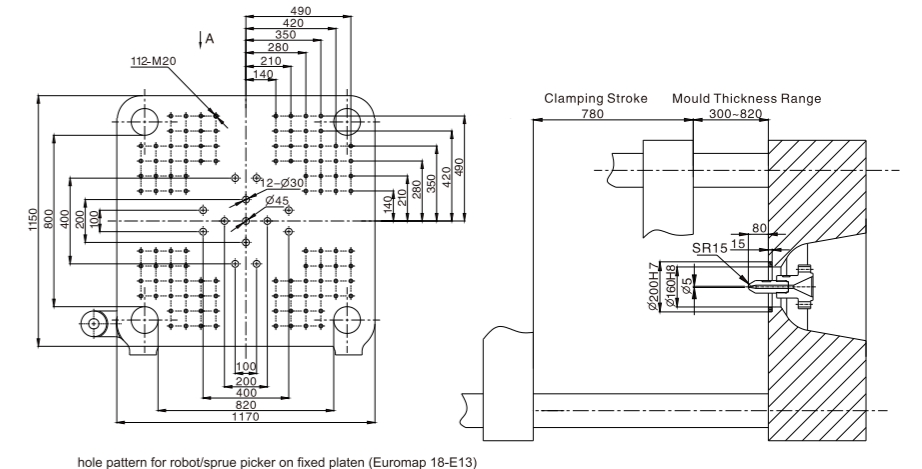

hole pattern for robot/sprue picker on fixed platen (Euromap 18-E13)

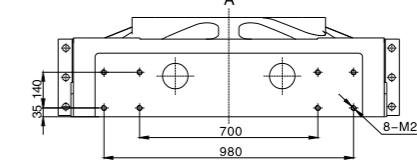

500SeIII

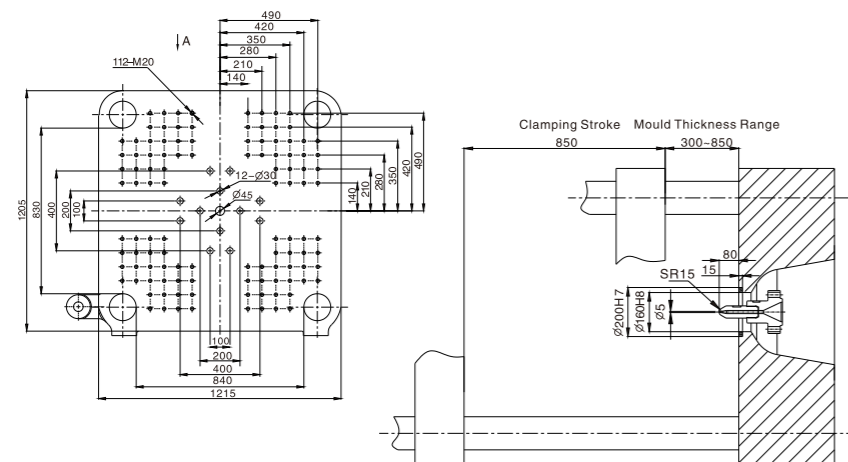

hole pattern for robot/sprue picker on fixed platen (Euromap 18-E13)

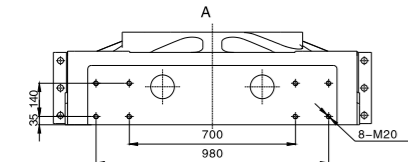

560SeIII

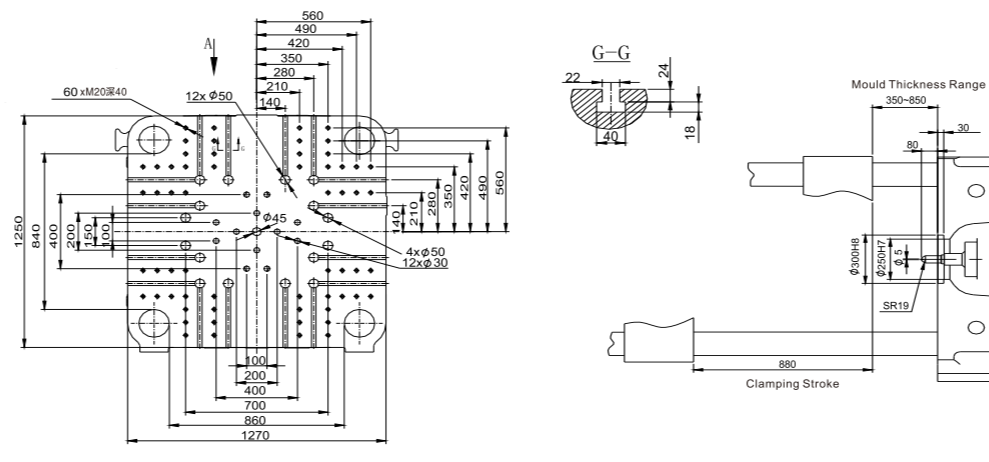

hole pattern for robot/sprue picker on fixed platen (Euromap 18-E13)

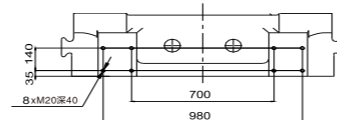

660SeIII

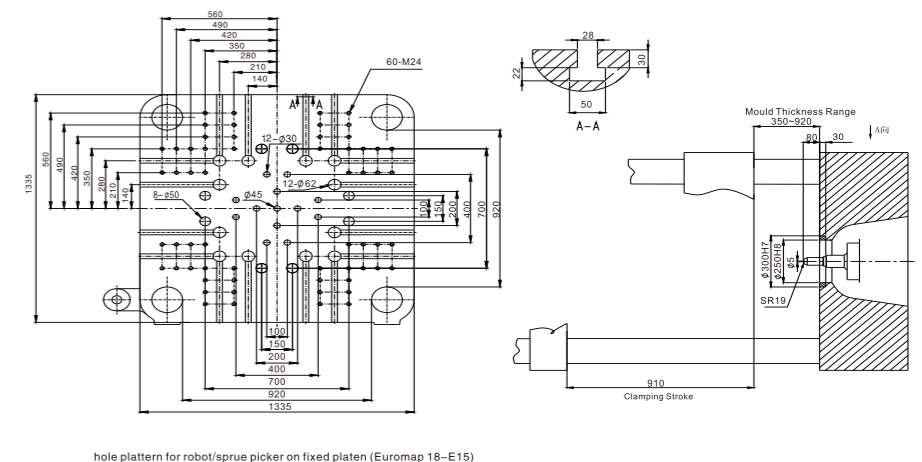

hole pattern for robot/sprue picker on fixed platen (Euromap 18-E15)

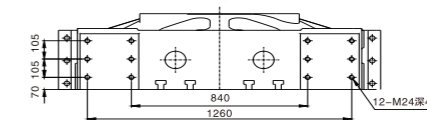

SeIII series (60-2200Ton)

The benchmark for high-performance injection moulding machine



Platen/Nozzle Dimensions

750SeIII

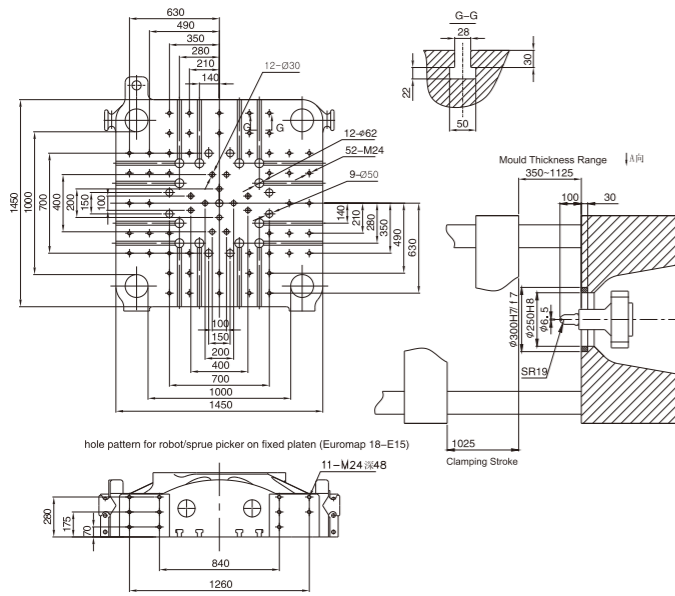

850SeIII

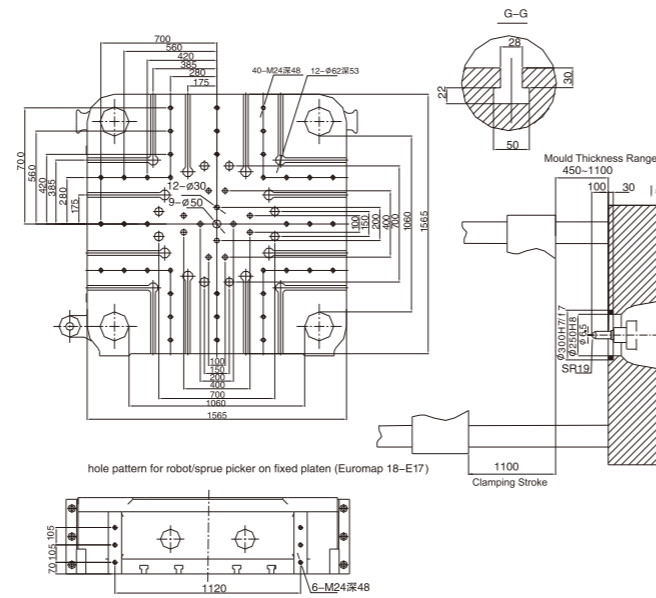

1000SeIII

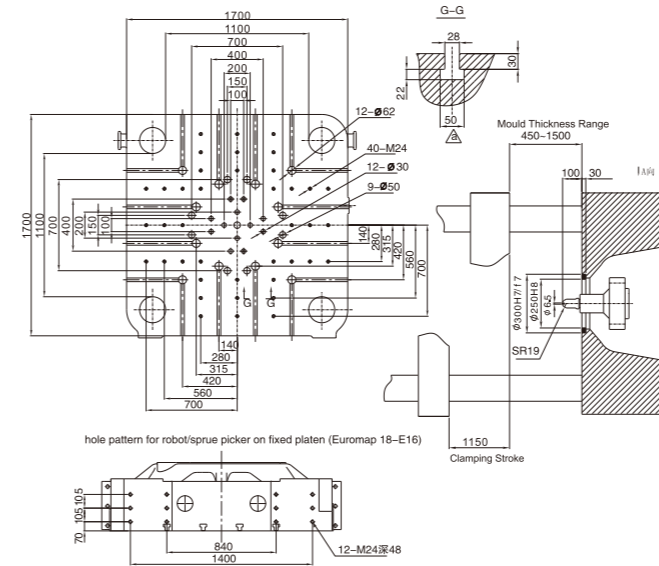

1250SeIII

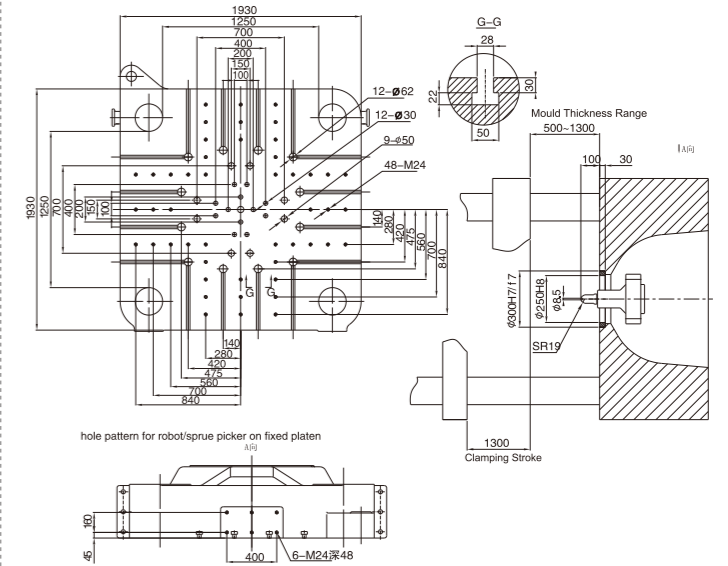

1500SeIII

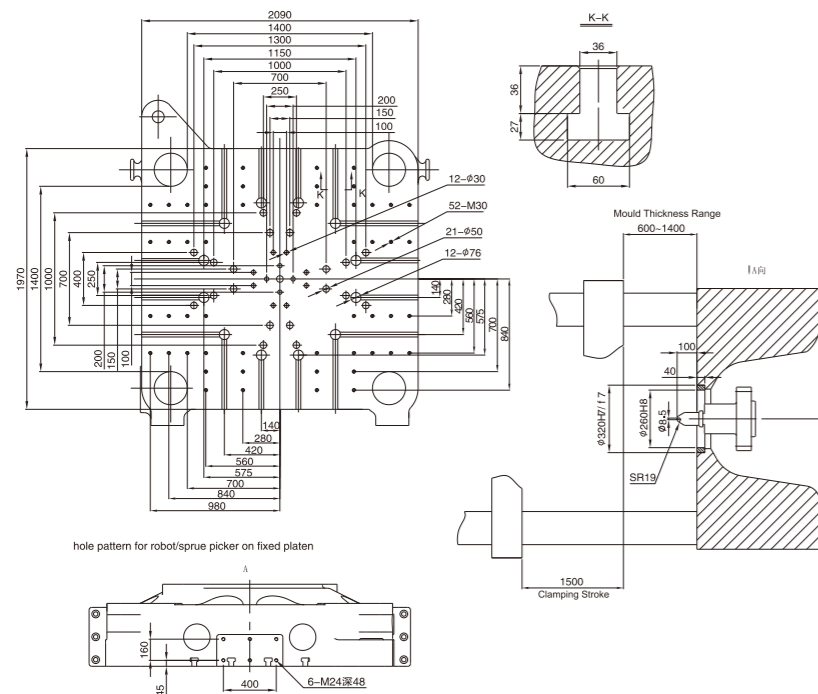

1800SeIII

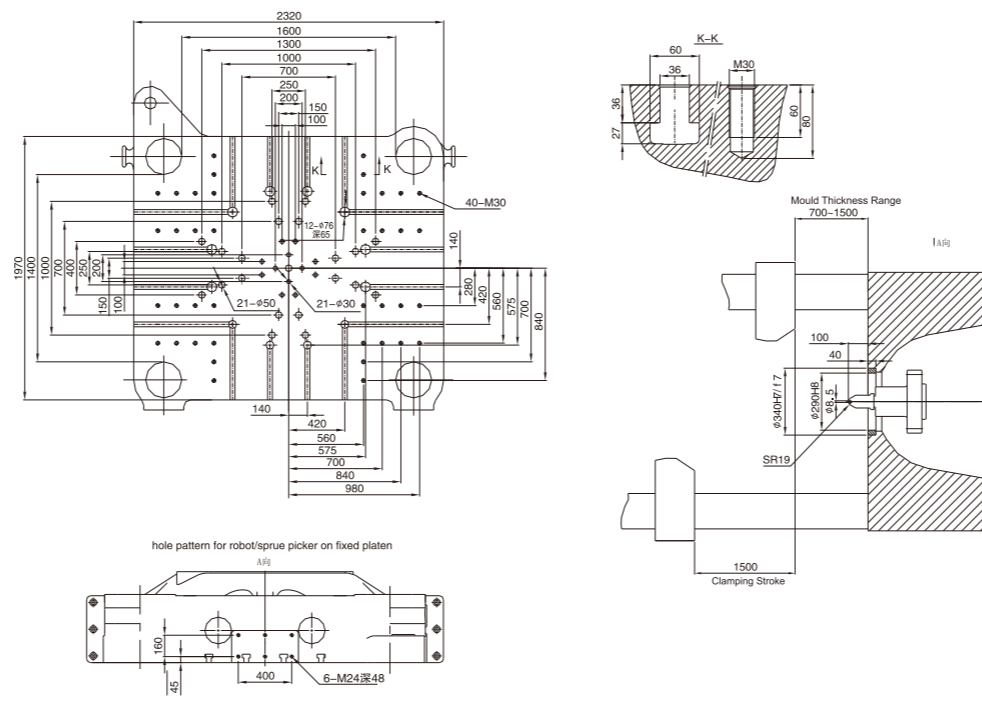

2200SeIII

